



Bi-Sonic



## DC 12038-03 NEW

**SIZE:**

120mm×120mm×38mm(4.72"×4.72"×1.50")

**CONSTRUCTION:**

- Die-cast aluminum housing
- Glass fiber reinforced plastic:  
Impeller are UL 94V-0 rating

**OPERATING TEMPERATURE:**

Ball bearing: -30°C to +75°C

Sleeve bearing: -10°C to +75°C

**INSULATION RESISTANCE**

10mega Ohm min.at 500 VDC  
(between frame and terminal)

**DIELECTRIC STRENGTH:**

5mA max. at 500 VAC 60Hz one minute  
(between frame and terminal)

**FUNCTION:**

- auto-restart option
- frequency generator or rotation detection signal option
- relay control option

**WEIGHT:**

380 grams

## Specifications:

MODEL NO.	BEARING	RATED	OPERATING	MAX.	MAX.	SPEED	MAX. AIR		MAX. AIR		NOISE
		VOLTAGE	VOLTAGE	CURRENT	INPUT		FLOW	PRESSURE			
		VDC	V	A	W	R.P.M.	m3/min	CFM	mmH2O	inH2O	dB-A
BP1203812M-03	Ball	12	10.2~13.8	1.00	12.00	2600	3.14	111.0	6.50	0.26	39
SP1203812M-03	SLEEVE										
BP1203812H-03	Ball	12	10.2~13.8	1.10	13.20	3100	3.69	130.4	9.15	0.36	44
SP1203812H-03	SLEEVE										
BP1203812HH-03	Ball	12	10.2~13.8	1.80	21.60	3600	4.29	151.5	11.80	0.46	48
SP1203812HH-03	SLEEVE										
BP1203812HU-03	Ball	12	10.2~13.8	1.40	16.80	4200	5.01	177.0	16.00	0.63	52.3
SP1203812HU-03	SLEEVE										
BP1203824M-03	Ball	24	20.4~27.6	0.60	14.40	2600	3.14	111.0	6.50	0.26	39
SP1203824M-03	SLEEVE										
BP1203824H-03	Ball	24	20.4~27.6	0.80	19.20	3100	3.69	130.4	9.15	0.36	44
SP1203824H-03	SLEEVE										
BP1203824HH-03	Ball	24	20.4~27.6	1.10	26.40	3600	4.29	151.5	11.80	0.46	48
SP1203824HH-03	SLEEVE										
BP1203848M-03	Ball	48	40.8~55.2	0.18	8.64	2600	3.14	111.0	6.50	0.26	39
SP1203848M-03	SLEEVE										
BP1203848H-03	Ball	48	40.8~55.2	0.40	19.20	3100	3.69	130.4	9.15	0.36	44
SP1203848H-03	SLEEVE										
BP1203848HH-03	Ball	48	40.8~55.2	0.50	24.00	3600	4.29	151.5	11.80	0.46	48
SP1203848HH-03	SLEEVE										
BP1203848HU-03	Ball	48	40.8~55.2	0.60	28.80	4500	5.39	190.4	18.89	0.74	54
SP1203848HU-03	SLEEVE										
BP1203848HV-03	Ball	48	40.8~55.2	0.80	38.40	5200	6.34	223.9	25.05	0.99	60.2
SP1203848HV-03	SLEEVE										

Dimensions (mm)

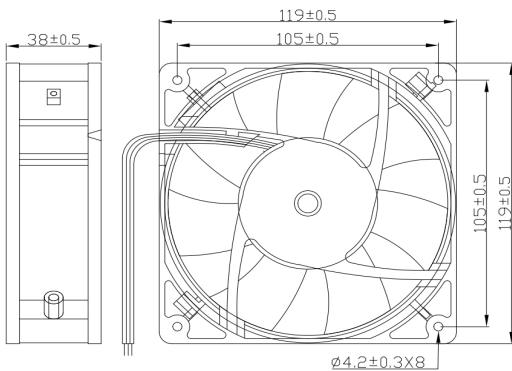

Performance Curve

