



Bi-Sonic

## EC 12025-03



**SIZE:**

120mm×120mm×25mm(4.72"×4.72"×0.98")

**CONSTRUCTION:**

Glass fiber reinforced plastic:

Impeller and housing PBT are UL 94V-0 rating

Lead wire available

EC(AC to DC) brushless motor

With rotor lock protection(auto restart)

**DIELECTRIC STRENGTH:**

WITHSTANDING at 1500V AC 60Hz one minute

( between frame and terminal)

**INSULATION RESISTANCE**

10mega Ohm min.at 500 VDC ( between frame and terminal)

**OPERATING TEMPERATURE:**

Ball bearing: -10°C to +75°C

**FUNCTION(Optional):**

IP55

**WEIGHT:**

110 grams

### Specifications:

MODEL NO.	BEARING	RATED	FREQUENCY	OPERATING	MAX.	MAX.	SPEED	MAX. AIR FLOW		MAX. AIR		NOISE
		VOLTAGE		VOLTAGE	CURRENT	INPUT		m3/min	CFM	mmH2O	inH2O	
		VEC	HZ	RANGE	mA	POWER						
EC12025LB-03	Ball	115 230	60 50	90~250	75 70	3	2000	1.9	66.5	2.2	0.1	33.8

Dimensions (mm)

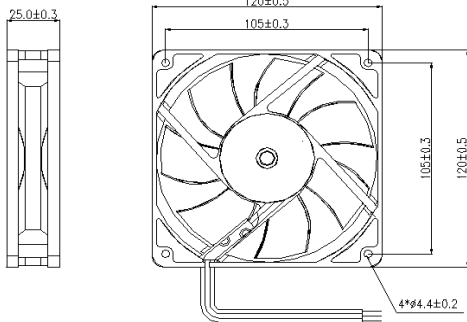

Performance Curve

