



Bi-Sonic



## EC 8025-03

### SIZE:

80mm×80mm×25mm(3.15"×3.15"×0.98")

### CONSTRUCTION:

Glass fiber reinforced plastic: Impeller and housing PBT are UL 94V-0 rating□

EC(AC to DC) brushless motor

Lead wire available

With rotor lock protection(auto restart)

### DIELECTRIC STRENGTH:

WITHSTANDING at 1400V AC 60Hz one minute (between frame and terminal)

### INSULATION RESISTANCE

10mega Ohm min.at 500 VDC (between frame and terminal)

### OPERATING TEMPERATURE:

Ball bearing: -10°C to +75°C

### WEIGHT:

75 grams

## Specifications:

MODEL NO.	BEARING	RATED		OPERATING		MAX. INPUT POWER	MAX. SPEED	MAX. AIR FLOW		MAX. AIR PRESSURE		NOISE
		VOLTAGE	FREQUENCY	VOLTAGE	RANGE			CURRENT	R.P.M.	m3/min	CFM	
EC8025MB-03	Ball	115	60	90~250	0.05	3	2700	1.0	35.4	3.4	0.1	32
		230	50									
EC8025HB-03	Ball	115	60	90~250	0.06	3	3300	1.2	41.5	5.0	0.2	36.8
		230	50									

### Dimensions (mm)

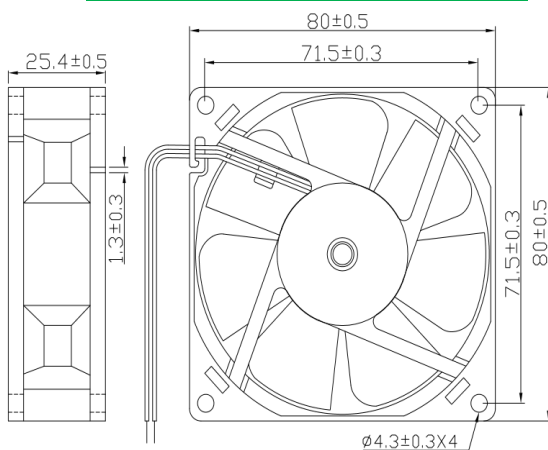

### Performance Curve

